

3M

Headset Intercom System

Model C960

Replacement Parts and Service

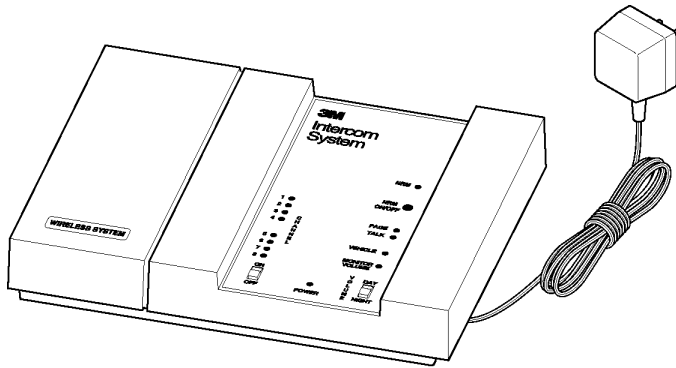

Base Station

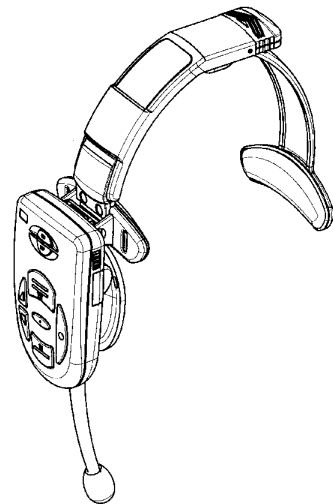

Headset

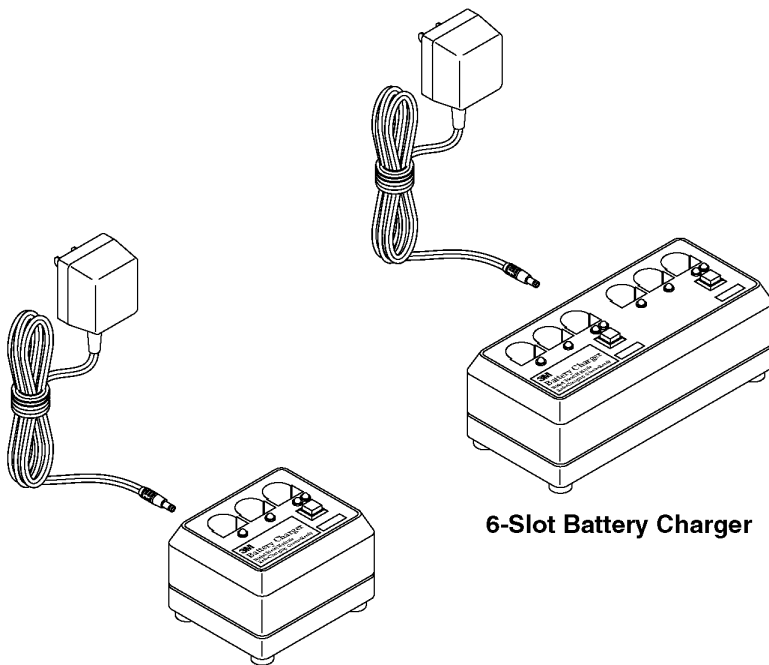

3-Slot Battery Charger

6-Slot Battery Charger

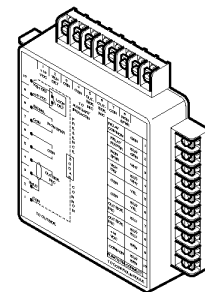

Interconnect Module

(this page intentionally left blank)

Headset Assembly

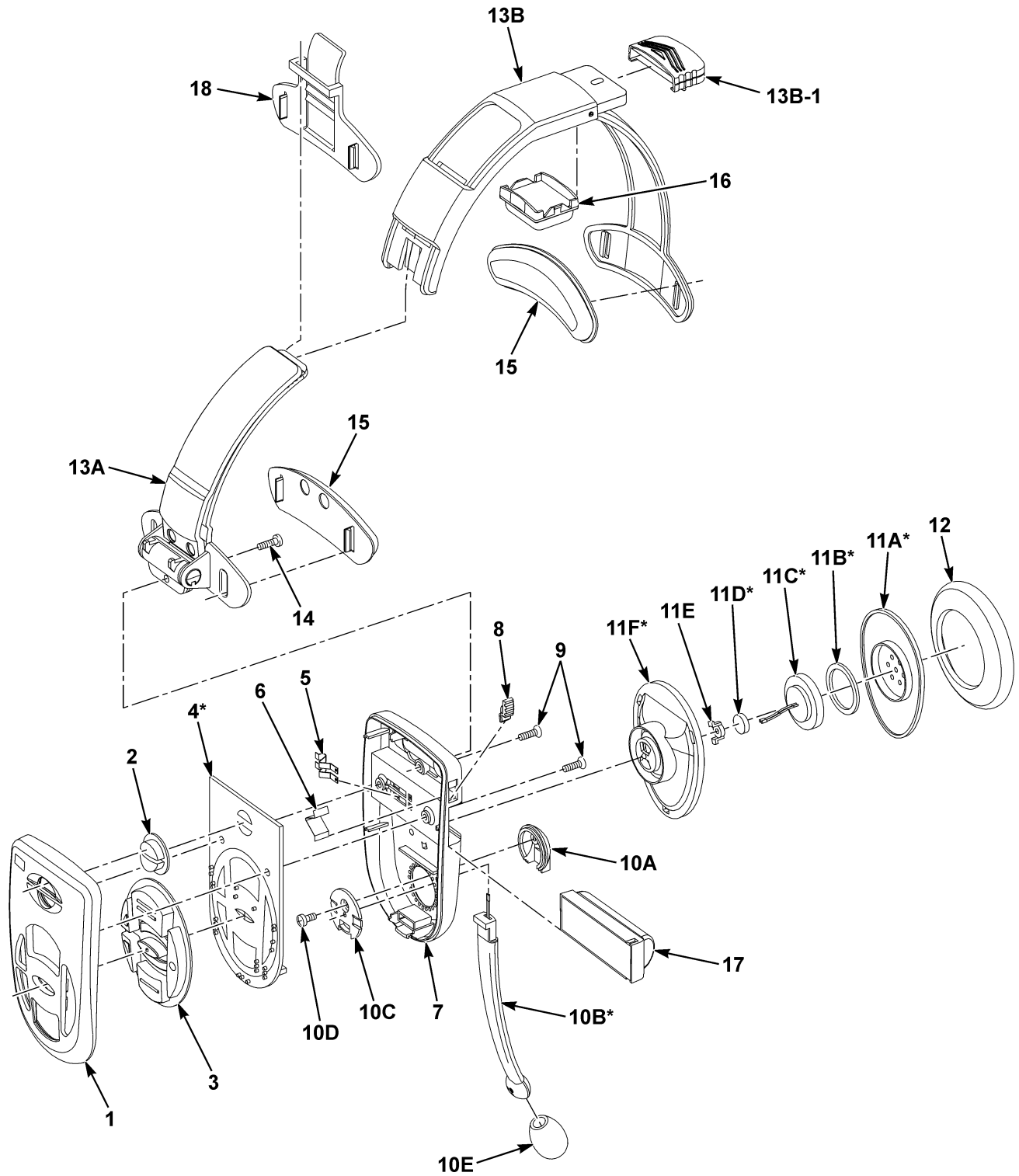

SP-258R

Item No.	Part Number	Description	Qty.
0	78-6911-4492-3	HEADSET ASSEMBLY, Model C920AC	1
1	78-8095-0525-4	OUTER CASE (with logo)	1
2	78-8095-0557-7	ON/OFF KEYPAD	1
3	78-8095-0574-2	KEYPAD	1
4*	Not Available	HEADSET PWA	1
5	78-6911-4630-8	BATTERY TERMINAL Kit (5 pairs)	2
6	78-8095-0556-9	SPRING, Battery Release Button	2
7	78-8095-0559-3	INNER CASE ASSEMBLY	1
8	78-8095-0551-0	BUTTON, Battery Release	1
9	26-1014-3441-8	SCREW, Flat Head, CS, Hi-Low, 4-40 x 1/4"	2
9A	26-1002-5298-5	SCREW, Flat Head, Mach, 4-40 x .375	2
10	78-8095-0523-9	MIC BOOM ASSEMBLY (Replacement)	1
10A	78-8095-0566-8	BASE, Mic Boom	1
10B*	Not Available	BOOM, Mic	1
10C	78-8095-0565-0	LOCK, Mic Boom	1
10D*	Not Available	SCREW, Pan Head, 4-40 x 1/4"	1
10E	78-6911-4506-0	MIC WINDSCREEN (Package of 10)	1
11	78-8095-0524-7	SPEAKER ASSEMBLY (Replacement)	1
11A*	Not Available	EAR CUP, Speaker Cover	1
11B*	Not Available	GASKET, Speaker	1
11C*	Not Available	SPEAKER ASSEMBLY	1
11D*	Not Available	FOAM, Speaker	1
11E	78-8095-0563-5	JOINT, Ear Cup	1
11F*	Not Available	EAR CUP	1
12	78-6911-4505-2	EAR PAD (Package of 10)	1
13A	78-8095-0583-3	HEADBAND ASSEMBLY, Adjustable	1
13B	78-8095-0582-5	HEADBAND ASSEMBLY, Main	1
13B-1	78-8095-0607-0	CAP, Headband Width Adjustment	1
14	26-1014-3439-2	SCREW, Pan Head, 6-32 x 7/16"	1
15	78-6911-4510-2	SIDE PAD ASSEMBLY (Package of 10)	2
16	78-6911-4507-8	TOP PAD ASSEMBLY (Package of 5)	1
17	78-6911-4491-5	BATTERY ASSEMBLY	1
18	78-8095-0591-6	CAP/VISOR CLIP (Package of 5)	1

* - Not available separately - included with (replacement) assembly.

Replacing the Headset Speaker

Tools Required:

- Phillips screwdriver
- Razor blade
- Small, flat-blade screwdriver (jeweler's type)
- Needlenose pliers

Procedure:

1. Remove the ear pad as shown in Figure 3-1.

2. Remove the headband and the battery. See Figure 3-2.
3. Remove the outer case and the two keypads and set them aside. See Figure 3-2.

Caution

The headset PWA is **not** fastened to the inner case assembly. Be careful not to strain the speaker battery contact and microphone leads that are connected to the PWA.

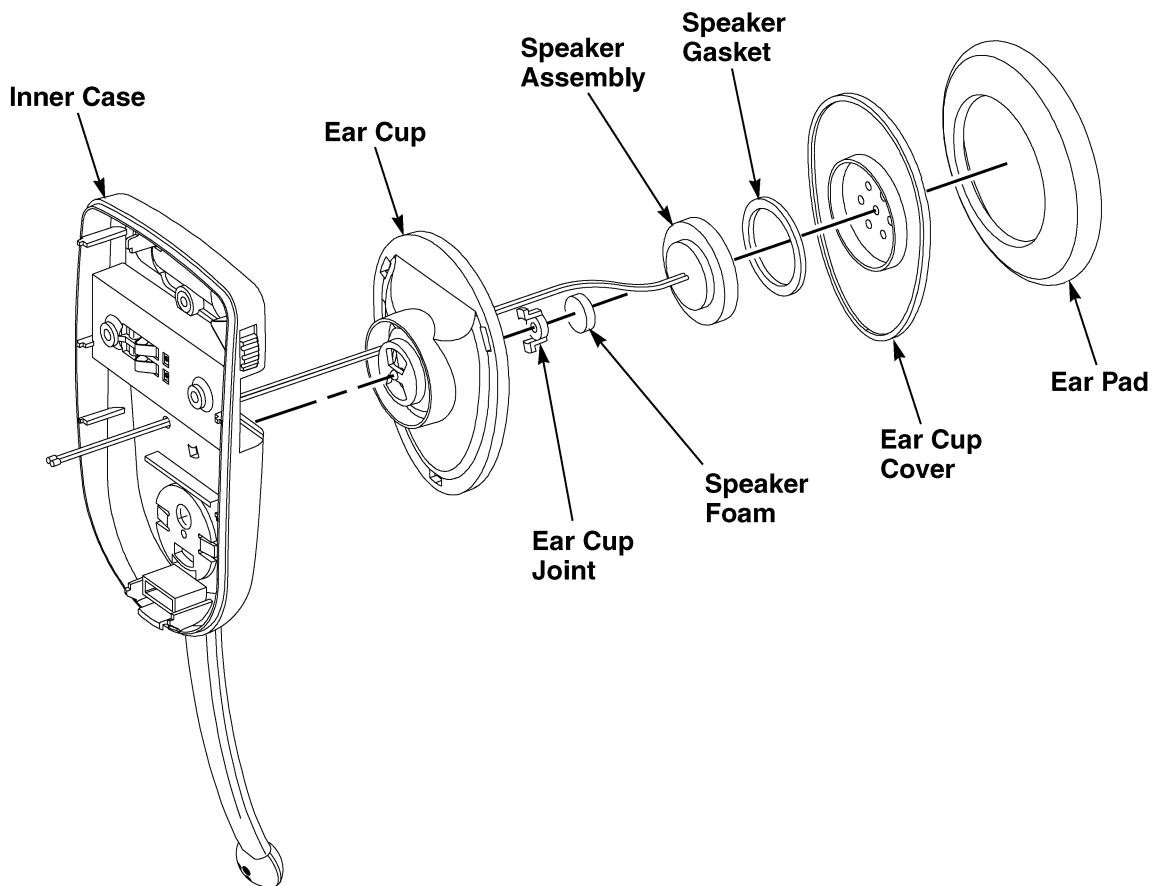

SP-304A

11Figure 3-1.

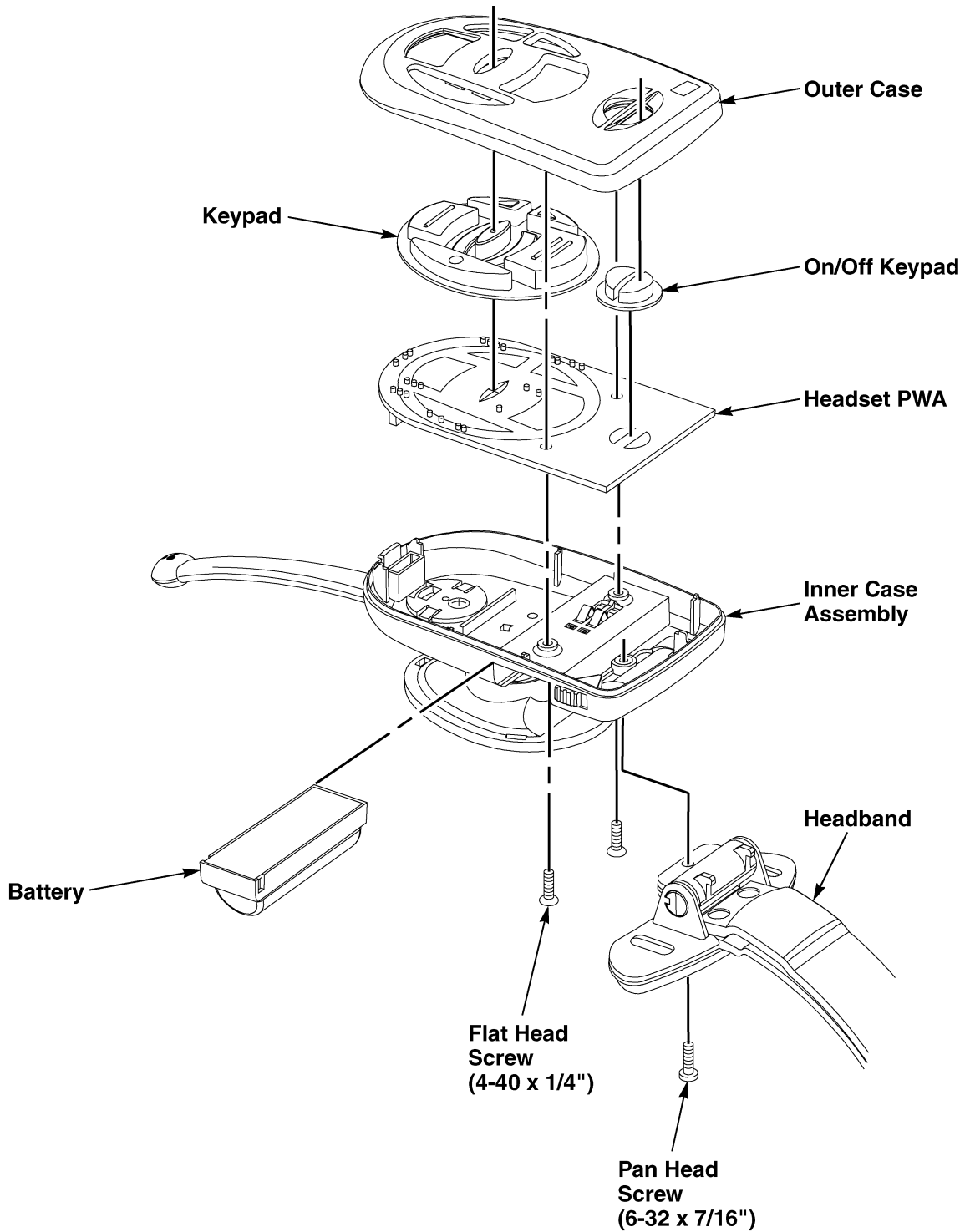

SP-303A

Figure 3-2.

4. Carefully unplug the microphone and speaker connectors from the headset PWA and set the PWA aside. See Figure 3-3.
5. Remove the connector terminals from the speaker connector housing as shown in Figure 3-4.

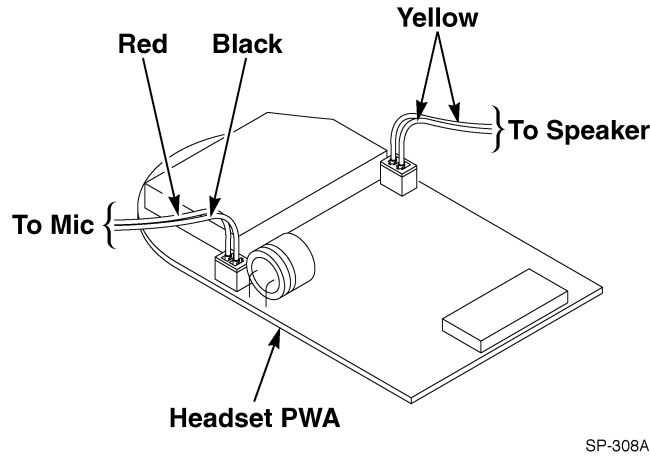

Figure 3-3.

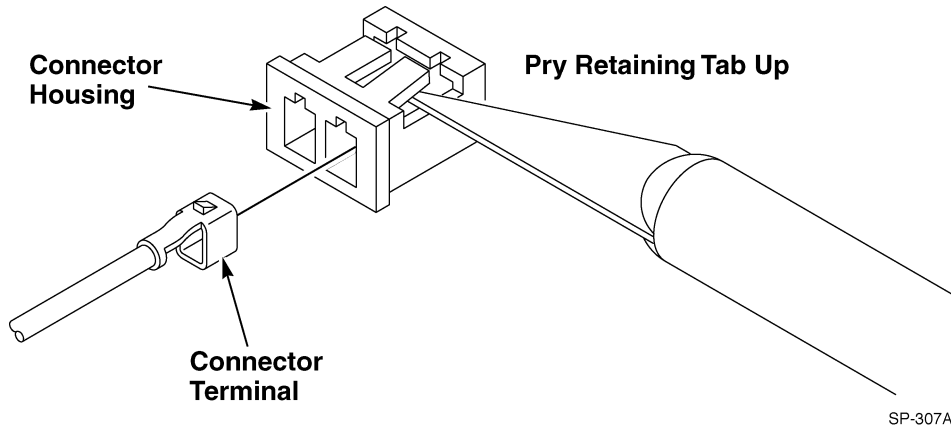
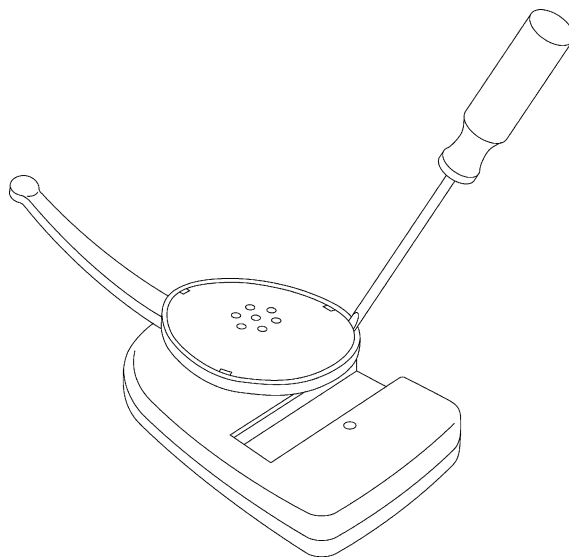

Figure 3-4.

6. Remove the ear cup cover from the ear cup:
 - a. If the cover is sealed to the cup, carefully cut through the epoxy seal using a sharp razor blade.
 - b. Carefully insert a small, flat-blade screwdriver between the cover and the ear cup at the point indicated in Figure 3-5 and pry the cover out of the ear cup.
7. Remove the ear cup joint. See Figure 3-1.
8. Carefully withdraw the speaker leads from the hole in the inner case.
9. Install the new headset speaker and reassemble the headset in the reverse order of disassembly.

Note

Be sure to correctly align the speaker foam and speaker gasket with the ear cup cover. Refer to Figure 3-1.



SP-309A

Figure 3-5.

Replacing the Mic Boom Assembly

Tools Required:

- Phillips screwdriver
- Razor blade
- Small, flat-blade screwdriver (jeweler's type)
- Needlenose pliers

Procedure:

1. Remove the ear pad as shown in Figure 3-1.
2. Remove the headband and the battery. See Figure 3-2.
3. Remove the outer case and the two keypads and set them aside. See Figure 3-2.
4. Carefully unplug the microphone and speaker connectors from the headset PWA, and set the PWA aside. See Figure 3-3.
5. Remove the mic boom lock as shown in Figure 3-6.
6. Remove the mic boom base from the mic boom. See Figure 3-6.
7. Route the mic boom assembly through the hole in the inner case assembly. See Figure 3-6.
8. Install the new mic boom assembly and reassemble the headset in the reverse order of disassembly.

Caution

The headset PWA is **not** fastened to the inner case assembly. Be careful not to strain the speaker battery contact and microphone leads that are connected to the PWA.

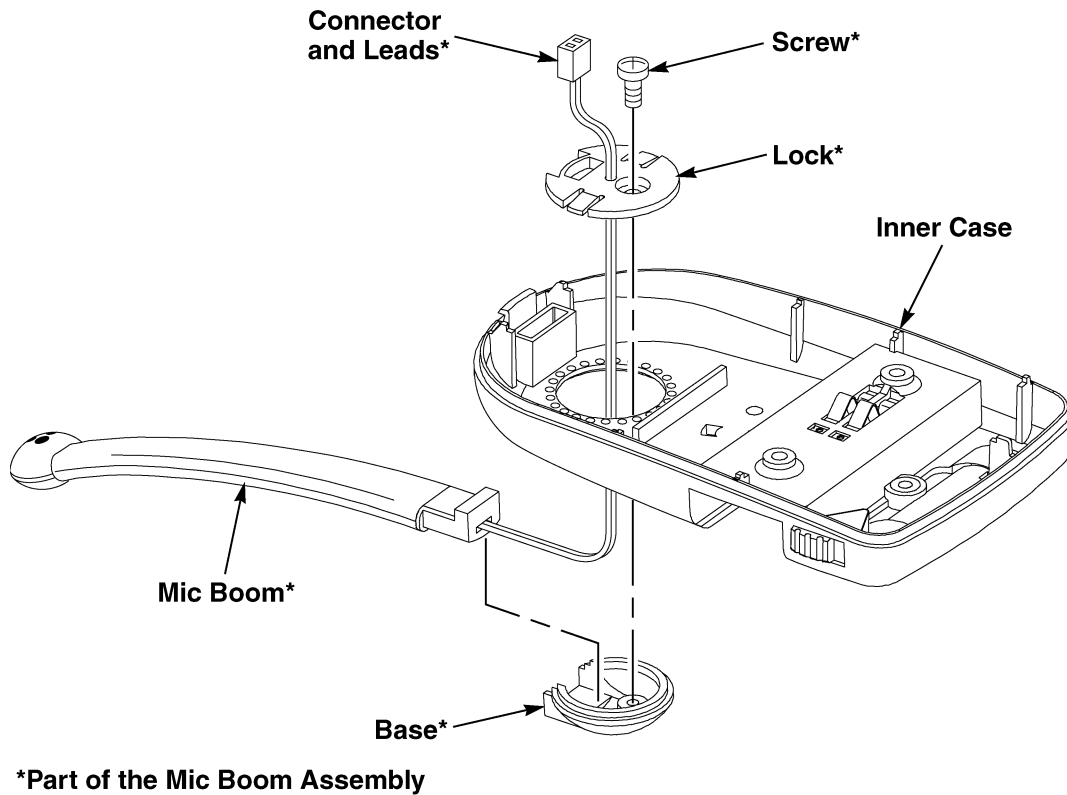

SP-305A

Figure 3-6.

Replacing the Battery Release Button Spring

Tools Required:

- Phillips screwdriver
- Needlenose pliers

Procedure:

1. Remove the battery. See Figure 3-1.
2. Remove the outer case and the two keypads and set them aside. See Figure 3-2.

3. Carefully unplug the microphone and speaker connectors from the headset PWA, and set the PWA aside. See Figure 3-3.
4. Lift the battery release button spring out of the retainers in the housing. See Figure 3-7.
5. Install the new battery release button spring, and reassemble the headset in the reverse order of disassembly.

Caution
<p>The headset PWA is not fastened to the inner case assembly. Be careful not to strain the speaker battery terminals and microphone leads that are connected to the PWA.</p>

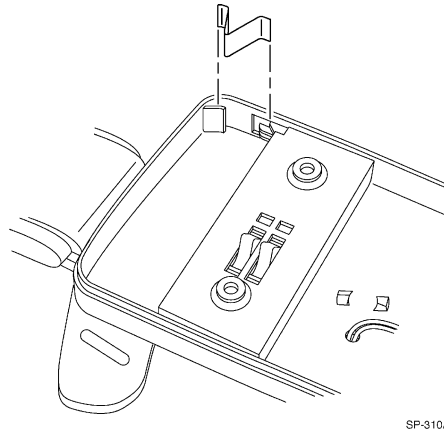

Figure 3-7.